



.55 AIRCRAFT ENGINE OWNERS MANUAL

According to our RC experiences years developments and improvements also combined CNC high-tech processing and here you go the series of SH aircraft engine with great performance and max output efficiency.

This engine has a unique groove lubricant design and no need piston ring inside of cylinder.

The engine comes with max torque, high speed, lasting life, easy adjustment and excellent cooling.

That's why we strongly believe it will be the best choice for all the aircraft pilots. Suitable for all .40-.50 size model aircrafts on the market.

⊙ Proper run-in (break-in) of the engine is very important step in ensuring that you get the highest performance and lifetime of your engine.

★ Please make sure the engine is mounted to your model securely and that the fixed screw is locked tightly to the carburetor in case of any issues causing unsmooth performance.

- Disassembled the rear cover of the engine and use nitro fuel clean up the internal anti-rust oil and all the burrs before install into the aircraft.
- Install the carburetor at the engine inlet according to the direction required by the aircraft model.
- Fuel suggestion: 5%~30% nitro fuel and SH factory specified manufacture R4 plug.
- Propeller installation: Propeller size of 11"x7" is recommended and the installation angle suggested as the below drawing (1) showed.

★ An inappropriate (too big) propeller may cause the engine to become overloading and potentially shorten its life.

★ Please make sure the propeller is tightly locked in case of any issues occurred by an accident.

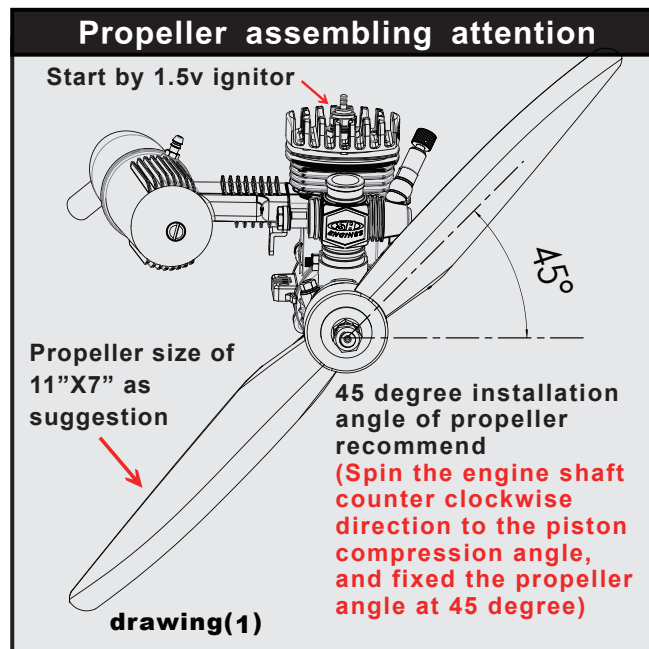

Carburetor Setting and Run-In Procedure

1. First, adjust the idling screw to the position showed in drawing (2) of mark ③, fully closed from the bottom and open approx. 1.5mm. For needle adjustments, image the slot in the needle is the hour band on a clock and only adjust the needle from 1-2 hour increments each changes.

2. First stage of run-in:

The main needle and low speed needle are preset from the factory. Please turn the main needle see above in drawing (2) of mark ①, Set the main needle at 2 turns and 6 hours from the bottom and low speed needle at 2 turns and 9 hours from the bottom. After that, open the carburetor about 1/3 position and block the carburetor inlet by hand and spin the engine counter-clockwise direction to help push fuel into the carburetor inside the engine. Connect the plug igniter and apply an electric starter to start the engine, keeping the engine staying in mid-range running and then you can remove the plug igniter.

3. Engine RPM observation:

You can turn the main speed needle counter clockwise 2 hours if the engine reaches over more than 6000 RPM's. Adjust in 2 hours increments at a time until the engine is running rich.

You can turn the main needle clockwise 2 hours if the engine is too rich and stops running. Adjust in 2 hour increments at a time until the engine returns to a rich and smooth-running condition.

At this stage roughly required 500cc of fuel running through.

★ The exhaust should emit lots of dark blue smoke, indicating that the engine is in rich condition.

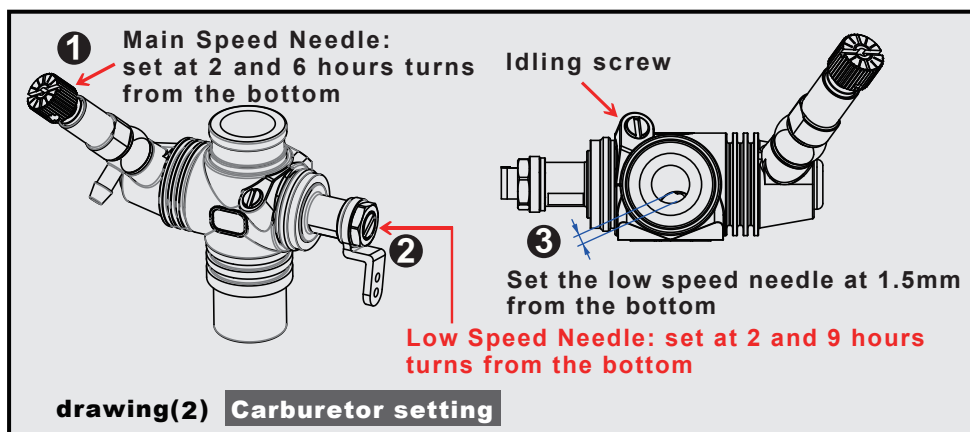

4 . Low speed needle adjustment:

Adjust the idling screw to the position showed in drawing(2) of mark ③ , fully closed from the bottom and open approx. 1.0mm. If the engine idle speed is high and continues to increase and not slow down, it's too lean and the low speed needle needs to be turned counter clockwise 2 hours until idle is stable. If the engine at idle speed is too low and leads to stalling, it's too rich and then low speed needle needs to be turned clockwise about 1 hours until the idle is stable. Stay around at 2600 RPM for the best idle speed of this time.

5.Second stage of

run-in:Set the throttle to fully open position for accelerating, to set the main needle adjustment.

The engine needs to stay in a rich condition during the run-in procedure and the exhaust should emit a lot of fuel and white/blue smoke at the same time.

You can turn the main speed needle counter clockwise 2 hours if the engine reaches over more than 8000 RPM.

Adjust in 2 hour increments at a time until engine returns to stable running under 7000 RPM.

You can turn the main needle clockwise 2 hours if the engine is too rich, leading to stalling.

Make adjustment in 2 hour increments at a time until the engine is back to a rich condition in mid-range running.

At this stage roughly required 400cc of fuel running through.

★Always watch out for the engine speed and how much fuel is running through, make sure engine speed stays under 8000 RPM or will caused the engine damage when engine running too lean condition.

6.After the first and second stage run-in procedure, preliminary engine run-in is complete, but the engine is still new. At this stage, we can proceed to our first initial flight.

Make sure the receiver battery is fully charged, fuel tank is full and the servos have the correct forward and reverse direction. Then start the engine and allow a 2 minutes warm up in the mid speed range of running.

Put the aircraft model on a flat surface, holding tight and set the throttle position to fully open to adjust the main needle. Hold the model with the nose up around 50-60 degrees, the RPM will increase by approximately 9600 RPM and maintain that RPM. Then put the model back to a flat surface the RPM should return to the original rpm setting. Stay at 9400-9500 RPM for the best idle speed of this time.

After 2 flights, make slight main needle adjustments when the aircraft model is on a flat surface and set the engine to maintain 9600 RPM operation during flying. Finally, we have completed the run-in procedure and hope this engine brings more flying fun.

/ NOTES /

- 1.Kindly check the fuel line to ensure there is no leaking or clogged issue when the engine is running unsmooth.
- 2.Propeller size of 11"x7" or "12x6" is recommended. An inappropriate (too big) propeller may cause the engine to become overloading and potentially shorten its life. SH factory specified manufacture R4 plug is suggested.
- 3.The needles may need to be reset if there are any big changes to the operating flight environment.
(Hot / cold or any differences of the high altitude and low altitude)
- 4.Please clean up the spark plug and burn room after 1 gallon of fuel has run through the engine.
- 5.The fuel is flammable and dangerous; always stay away from sparks, heat or any other ignition source.
- 6.Provided warranty conditions has been met, your product will be repaired or replaced free of charge.
Repair or replacement decision is as the sole discretion of SH.
- 7.If the engine hasn't been used for a long time, the fuel may not get through the fuel line into the engine or carburetor. Please go check whether the fuel filter in the fuel tank is clogged, disassemble the carburetor and clean up. Adjust the needle setting as recommended and assembled the relative parts back.
Then restart the engine.

